



WaterMark

4032.2
Lic. No. 20137

To prevent debris from entering the valve, AVG recommends that external inline filters be fitted to the hot & cold inlets of the tempering valve.



Australian Valve Group

TEMPERING VALVE INSTALLATION INSTRUCTIONS

**TVA 15
and
TVA 20**

**FAILURE TO COMPLY WITH ALL ASPECTS OF THESE
INSTRUCTIONS MAY RESULT IN UNSAFE PERFORMANCE.
ALL INSTALLATIONS MUST COMPLY WITH AS/NZS3500 AND
ANY STATE OR LOCAL AUTHORITY REQUIREMENTS.**

CONTENTS

PAGE

WARNINGS	1-2
VALVE DIMENSIONS	3
VALVE SPECIFICATIONS & NOTES	4-5
VALVE ASSEMBLY	6
FITTING THE VALVE.....	7
INSTALLATION DIAGRAMS	8-11
TEMPERATURE ADJUSTMENT	12-13
ANNUAL CHECK / SERVICING THE VALVE	14
TROUBLE SHOOTING.....	15
WARRANTY	16-17

WARNING

Non-return valves are fitted to both inlets of this valve:

MAKE SURE the valve is protected from system debris by fitting the strainers provided. This is critical to ensure correct and safe system operation. In situations where the hot pressure may exceed the cold pressure and on pumped ring main systems, non-return valves **MUST** be fitted to **BOTH** inlets.

Flush the pipework thoroughly before fitting tempering valve:

It is **IMPORTANT** that all debris is flushed from the pipework prior to installing the valve. Not flushing the system properly is the most common cause of system difficulties.

Commission the valve:

All valves are factory – set to a nominal temperature of 50°C. **EACH VALVE** must be adjusted on site by the installer to ensure correct delivery of the desired mixed water temperature, as installation parameters can vary from site to site.

WARNING

IMPORTANT CHECKS:

- Measure and note all site parameters (pressures, temperature, etc) and check against the specifications of the chosen valve. If the site conditions are outside those specified for the valve then they must be rectified prior to installing the valve.
- **DO NOT** subject the valve to heat during installation as this may damage the valve internals.
- **DO NOT** fit valve on steam-supplied systems, but to water systems only.
- **DO NOT** install valve on low pressure installations
- **DO NOT** freeze valve. If the valve is installed in a situation where freezing is a possibility, then suitable insulation must be fitted to prevent damage to the valve.
- **DO NOT** use excess thread sealant (in liquid, tape or other form) as this may cause the valve to fail.
- **YELLOW CAP** - Storage water heaters
ORANGE CAP - Instantaneous / Continuous Flow / Solar

Leave a copy of these instructions with the customer for future reference. Fill in the details on the sticker provided and attach it to the water heater (or other suitable position or as specified by the Local Authority requirements). Recommend to the customer that the valve is checked annually to ensure its continued safe function.

Valve Dimensions

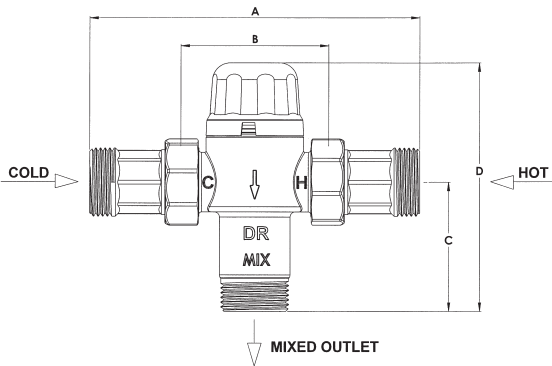

Model	A	B	C	D
TVA15	121.5	57.5	57	102.5
TVA20	129.5	57.5	57	102.5

VALVE SPECIFICATIONS

Cold water supply temperature:	5°C – 25°C
Hot Water supply temperature Standard (Yellow cap) TVA:	65°C – 85°C (1)notes
Hot Water supply temperature High Performance (Orange cap) TVA:	65°C – 99°C (1)notes
Adjustable outlet temperature range:	40°C – 50°C (2)notes
Factory set temperature:	50°C nominal <i>Must be commissioned on site by installer</i>
Accuracy of outlet temperature:	±3°C – tested to AS4032.2
Accuracy of outlet temperature:	±3°C – tested to AS4032.2
Minimum temperature differential (between hot supply and outlet temperature):	15°C (3)notes
Supply pressure, static:	1600kPa maximum
Supply pressure, dynamic:	500kPa maximum
Pressure supply imbalance, dynamic: (at time of commissioning)	2:1 maximum (4)notes
Maximum permitted pressure variation in either supply in order to control outlet temperature to ± 3°C: (from supply pressure at commissioning)	±10% maximum (5,6)notes
Flow rate minimum:	4 litres/min

Notes:

1. AS/NZS3500.4.2 Clause 1.6 requires the minimum hot water storage temperature to be 60°C to inhibit legionella bacteria growth.
2. For application outside of the requirements of AS4032.2 and AS/NZS3500 it is possible to set the valve as low as 35°C or as high as 56°C, depending on site condition.
3. This is the minimum difference required to ensure shut-off of outlet flow in the event of cold supply failure in accordance with AS4032.2, providing the valve is set between 40°C and 50°C.
4. The maximum permitted ratio of supply pressures, under dynamic (flow) conditions. For optimum performance it is recommended that the hot and cold pressures at commissioning are as close as possible to equal.
5. The maximum permitted variation in either supply pressure from the pressure at commissioning in order to control the outlet temperature to $\pm 3^{\circ}\text{C}$.
6. Note that rapid changes in supply pressure can result in a spike in the outlet temperature beyond $\pm 3^{\circ}\text{C}$. Following a rapid change in supply pressure it may take a number of seconds for the temperature to return to within a $\pm 3^{\circ}\text{C}$ limit. Steps should be taken on-site to eliminate any cause of rapid supply pressure variation.

Assembly

TVA15
TVA20

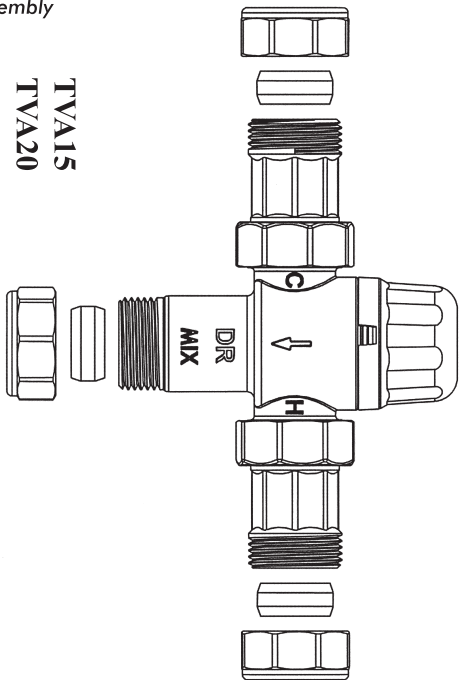

FITTING THE TEMPERING VALVE

- **The tempering valve must be fitted by an authorised person in accordance with the installation diagrams.** The mixed water outlet from the tempering valve should be used to supply outlets used primarily for personal hygiene purposes.
- It is recommended that **isolating valves** are fitted immediately upstream of both hot and cold inlets to the tempering valve. This allows convenient access to isolate the tempering valve in the event that the strainers need to be cleaned.
- It is recommended that the tempering valve be installed **as close as possible to the point of use**, however it may be fitted at the hot water heater or anywhere on the hot water supply line.
- If the tempering valve is fitted **at the point-of-use there must be a minimum one (1) metre pipe** run between the valve mixed water outlet connection and the tap.

System Supply Pressures

Tempering valves provide optimum performance when installed with hot and cold water supplies of equal dynamic pressure, i.e. with the water flowing. (The static supply pressures often give NO indication of the dynamic supply pressures). It is recommended that the hot and cold water supplies to each tempering valve be controlled via their own pressure control valve. In most domestic installations it should be possible to fit one control valve at the property boundary to control pressure to the whole site.

For commercial installations it is recommended to fit a pressure control valve on each inlet to the tempering valve.

Instantaneous Water Heater: Domestic Installation

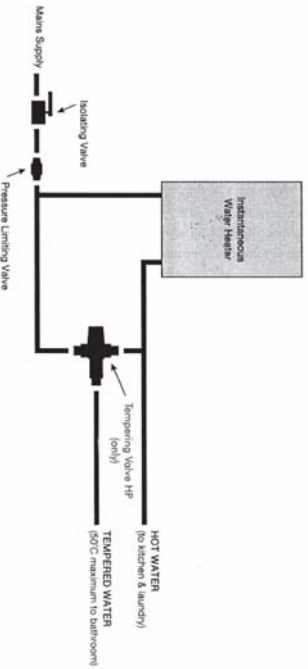

Use **ONLY** High Performance TVA on instantaneous systems.

Installation Diagram

Solar Water Heater - Domestic Installations

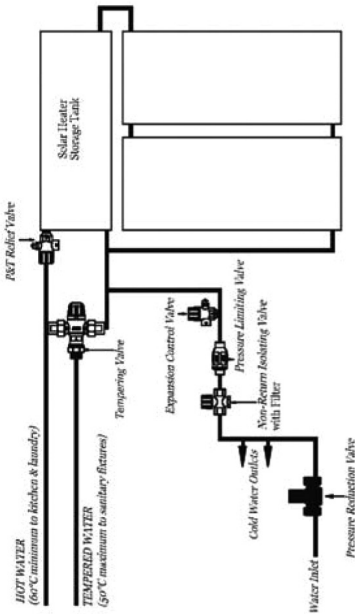

Schematic shows valve fitted at the heater. It is possible to mount the valve remote from the heater.

Installation Diagram

Mains Pressure Water Heater - Domestic Installations - Valve fitted remotely from the Heater

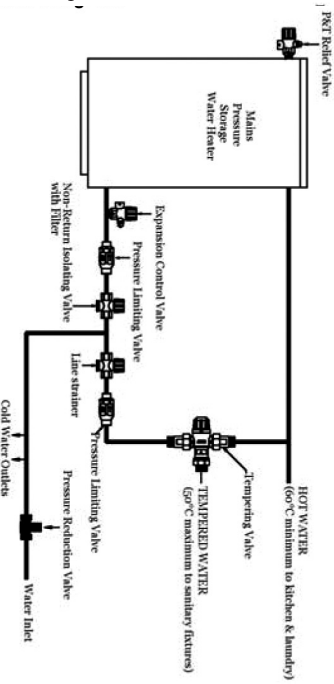

Installation Diagram

Heat Exchange Water Heater - Domestic Installations

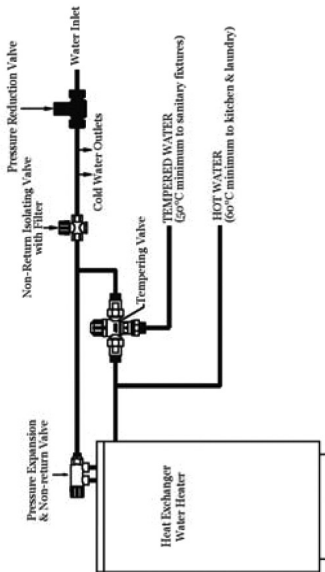

Schematic shows valve fitted at the heater. It is possible to mount the valve remote from the heater.

TEMPERATURE ADJUSTMENT

- Prior to adjusting the tempering valve it is necessary for the hot water heater to be switched on and delivering hot water at the recommended temperature. If the water heater has an adjustable thermostat it is recommended that the thermostat be set to 65°C. Ensure that the water heater has reached the set temperature before commissioning the tempering valve.
- Test the mixed water temperature at the nearest outlet being supplied by the tempering valve. The tap should be opened to allow a flow rate of at least four (4) litres/minute.
- A thermometer must be used at the nearest outlet to the valve to ensure the correct mixed water temperature is achieved.
- Allow the water to run for at least one minute to ensure the mixed water temperature has settled after each adjustment.
- To adjust the mixed outlet temperature of the tempering valve the cap should be removed to gain access to the adjusting spindle. Using the special tool moulded into the top of the cap rotate the adjusting spindle to achieve the required temperature. The spindle should be rotated – clockwise to reduce the temperature, anti-clockwise to increase the temperature – until the desired temperature is reached. See adjustment diagram and red tag fitted to the underside of the cap.
- Once the required temperature is achieved the cap should be snapped onto the valve to prevent accidental adjustment.
- When the tempering valve has been commissioned the commissioning label must be completed by the installer and affixed to the water heater in a prominent position (or other suitable position or as specified by the Local Authority).

Valve Adjustment

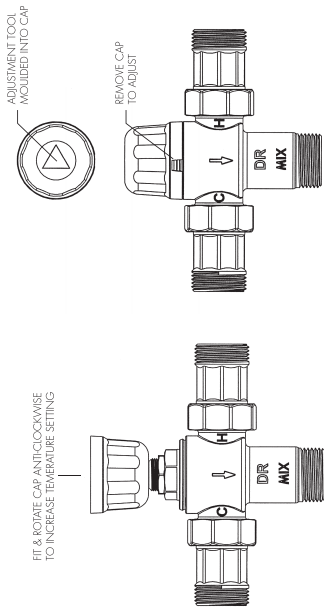

ANNUAL CHECK /SERVICING THE VALVE

- We recommend that the tempering valve is checked at least once per year to ensure its continued safe operation. For installations with bad or unknown water quality, or other detrimental supply conditions, it will be necessary to check the tempering valve more frequently.
- Using a thermometer the temperature should be checked at the same outlet used for commissioning in the first instance (refer to the commissioning label). If the temperature is more than 2°C from the commissioning temperature or outside the requirements of AS3500.4.2, refer to fault finding guide.
- There may be some variation in the temperature of the water from the tempering valve due to seasonal temperature variations in the cold water supply.
- The strainers can be easily accessed for cleaning via the large union connections to the tempering valve. (See the assembly diagram).
- If the water supply is of such poor quality that the tempering valve's strainers will continue to block, an additional filter or strainer should be fitted to the hot and cold inlets of the valve.
- The tempering valve itself cannot be serviced. If the valve fails it must be replaced. Do not attempt to disassemble the valve except to remove the snap-on cap and strainers for cleaning.
- Note that this tempering valve is a SAFETY VALVE. We recommend that it is replaced at intervals not exceeding 5 years.

TROUBLE SHOOTING

PROBLEM	CAUSES	WHAT TO DO
1. Unable to adjust mixed water temperature or valve is difficult to set.	<ul style="list-style-type: none"> • Inlet temperature are not within specific limits. • Hot and cold supplies are reversed. • Valve contains debris. • Strainers contain debris. 	<ul style="list-style-type: none"> • Ensure inlet temperatures are within the specified limits for the valve. • Refit the valve with Hot/Cold supplies fitted to the correct connections. • Flush water through valve. • Clean strainers
2. Unstable mixed temperature.	<ul style="list-style-type: none"> • Strainers are fouled. • Fluctuating supply pressures. 	<ul style="list-style-type: none"> • Clean strainers. • Install pressure reducing valves on hot and cold inlets to tempering valve.
3. Mixed temperature changing over time.	<ul style="list-style-type: none"> • Fluctuating supply pressures. • Strainers contain debris. 	<ul style="list-style-type: none"> • Install pressure reducing valves. • Clean strainers.
4. Either hot only or cold only water flowing from tap.	<ul style="list-style-type: none"> • Valve is incorrectly set. • Hot/Cold water is able to cross over to other inlet. (see point 1) 	<ul style="list-style-type: none"> • Adjust mixed temperature between 40 – 50°C as required. • Check non-return valve is not fouled. Clean if necessary.
5. No flow from the valve outlet.	<ul style="list-style-type: none"> • Hot or cold water supply failure. • Strainers blocked. 	<ul style="list-style-type: none"> • Restore inlet supplies and check the mixed water temperature. • Clean strainers.
6. Flow rate reduced or fluctuating.	<ul style="list-style-type: none"> • Valve or inlet filters blocked. • Fluctuating supply pressures. 	<ul style="list-style-type: none"> • Check valve and inlet filters for blockages. Clean or flush as required. • Install pressure reducing valves.
7. Mixed water temperature does not alter when valve is adjusted.	<ul style="list-style-type: none"> • Hot and cold supplies are reversed. 	<ul style="list-style-type: none"> • Refit the valve with Hot/Cold supplies fitted correctly.
8. Hot/Cold water cross flows into into each other.	<ul style="list-style-type: none"> • Non-return valves fouled. 	<ul style="list-style-type: none"> • Clear blockage. • Clean strainers.
9. Valve is noisy.	<ul style="list-style-type: none"> • Water velocity too high. (see AS/NZS 3500.1) 	<ul style="list-style-type: none"> • Reduce water velocity. (best achieved by fitting a pressure reducing valve).

AVG VALVE WARRANTY CONDITIONS

AVG warrant their valves against manufacturing defects for two (2) years subject to the following conditions:

1. In accordance with the National Plumbing and Drainage Code AS3500 and all relevant Statutory and Local Codes in the State or Territory in which the valve is installed by a licenced plumber.
2. The valve must be installed in accordance with the AVG installation instructions supplied with the valve.
3. The AVG warranty covers replacement of the valve only, at no charge. Costs to return the valve to AVG and replace the old valve are at the purchaser's expense.
4. The valve must be returned to AVG with a completed "AVG WARRANTY CLAIM FORM".
5. Where the valve forms part of a hot water system, the valve must be installed according to the hot water system manufacturers' specifications, in addition to all Statutory and Local State or Territory requirements.
6. The warranty is void if:
 - The valve has been damaged in any way.
 - The valve has been tampered with.
 - Incorrect installation.
 - The failure of valve is due to faulty manufacture/installation of the hot water system of which the valve forms a part.

- The valve has failed due to excessive pressure or temperature outside the valve specification.
 - The valve has failed due to non-compliance with the Plumbing Code AS3500.
 - The valve has failed due to foreign matter or scale build up inside the valve.
7. The AVG warranty does not cover any claims for damage to walls, carpets, furniture, foundations or any other consequential loss, directly or indirectly as a result of leakage from the valve, subject to any Statutory Provisions to the contrary.

AVG RESERVES THE RIGHT to change its specifications without prior notice and will not accept liability for any claim arising from such change.



AVG WA (Head Office)

Unit 2, 9-11 Noble St, Kewdale, WA, 6105

Tel: (08) 9353 2203 Fax: (08) 9353 2689

1800 AVG AUS (284 287)

www.avg.net.au

